



Intermediate Bulk Container (IBC) Tipper

When your IBC contains less than 100 litres, the springs gradually decompress causing a slope of 5% that optimises the drain of your tank. Specially designed for viscous and expensive liquids.



Solution with available retention tank – Contact us

Advantages of this product :

- Reduction of musculoskeletal disorders
- Avoid the use of an electric pump
- Less product = Savings
- Time saving (quicker flow)
- Rapid recovery of outlay
- Remaining volume < 0.1 % of the total capacity
- Positive environmental impact
- Very sturdy
- Easy and rapid implementation
- Without an external source of power (self-contained system)

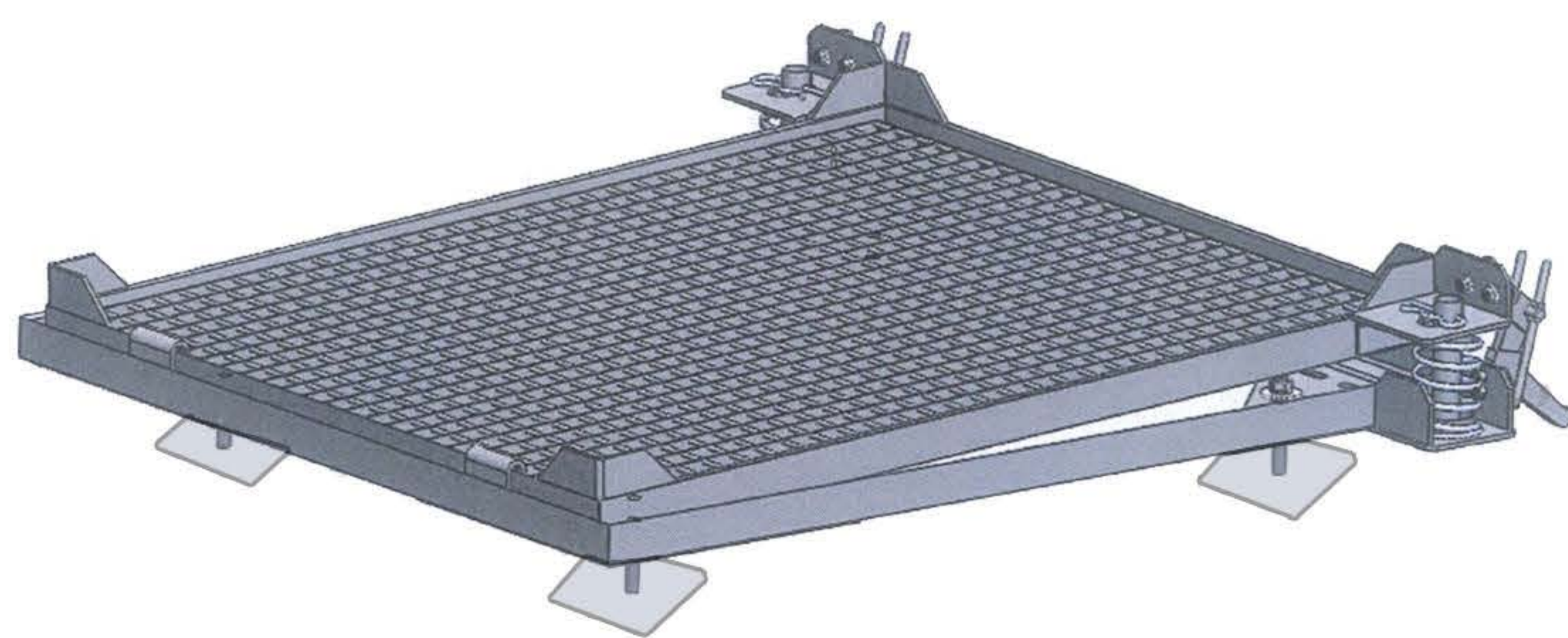

Dimensions : • Dim. Overall : 52.36 x 52.36 x 7.87 inches • Dim. Duckboard : 40.94 x 47.24 inches

Characteristics of the IBC tipper :

- Material : hot-dip galvanized steel
- Delivered with 4 height-adjustable skids
- Two year parts warranty

Available options :

- Kit quick-release cleat
- Frame to put it up (in height)
- Kit to integrate shelving